

ITEM	PART NUMBER	ITEM QTY	MATERIAL
1	Structure	1	
2	Plate_10-02	2	Steel, Mild
3	Hex Nut - M8	8	Steel, Mild
4	Hex Bolt - M8 x 25	8	Steel, Mild
5	Bottom Pipe Cover	1	Steel, Mild
6	RHS Panel Cover	1	Steel, Mild
7	Side Support	1	Steel, Mild
8	Panel Box	1	Steel, Mild

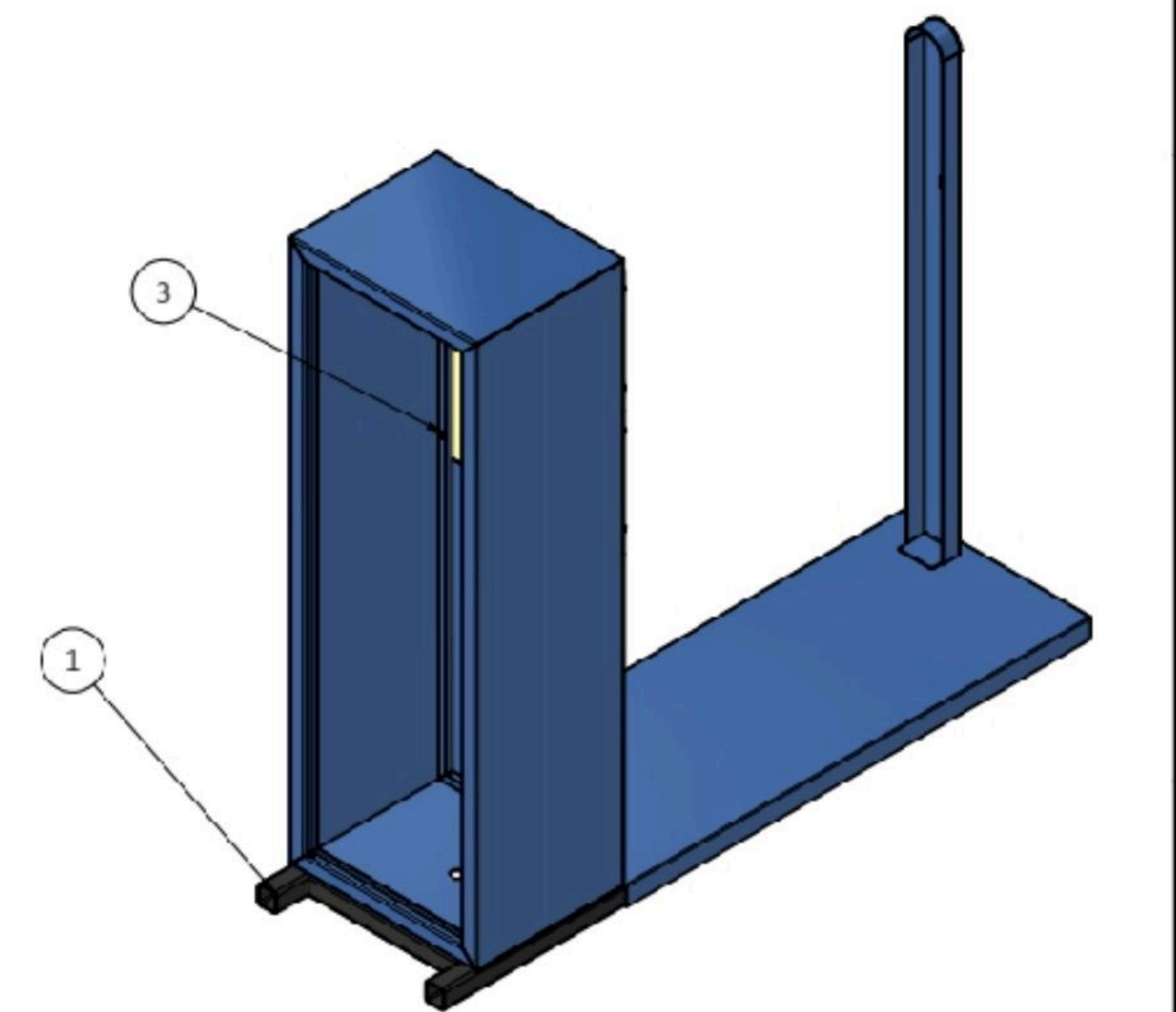
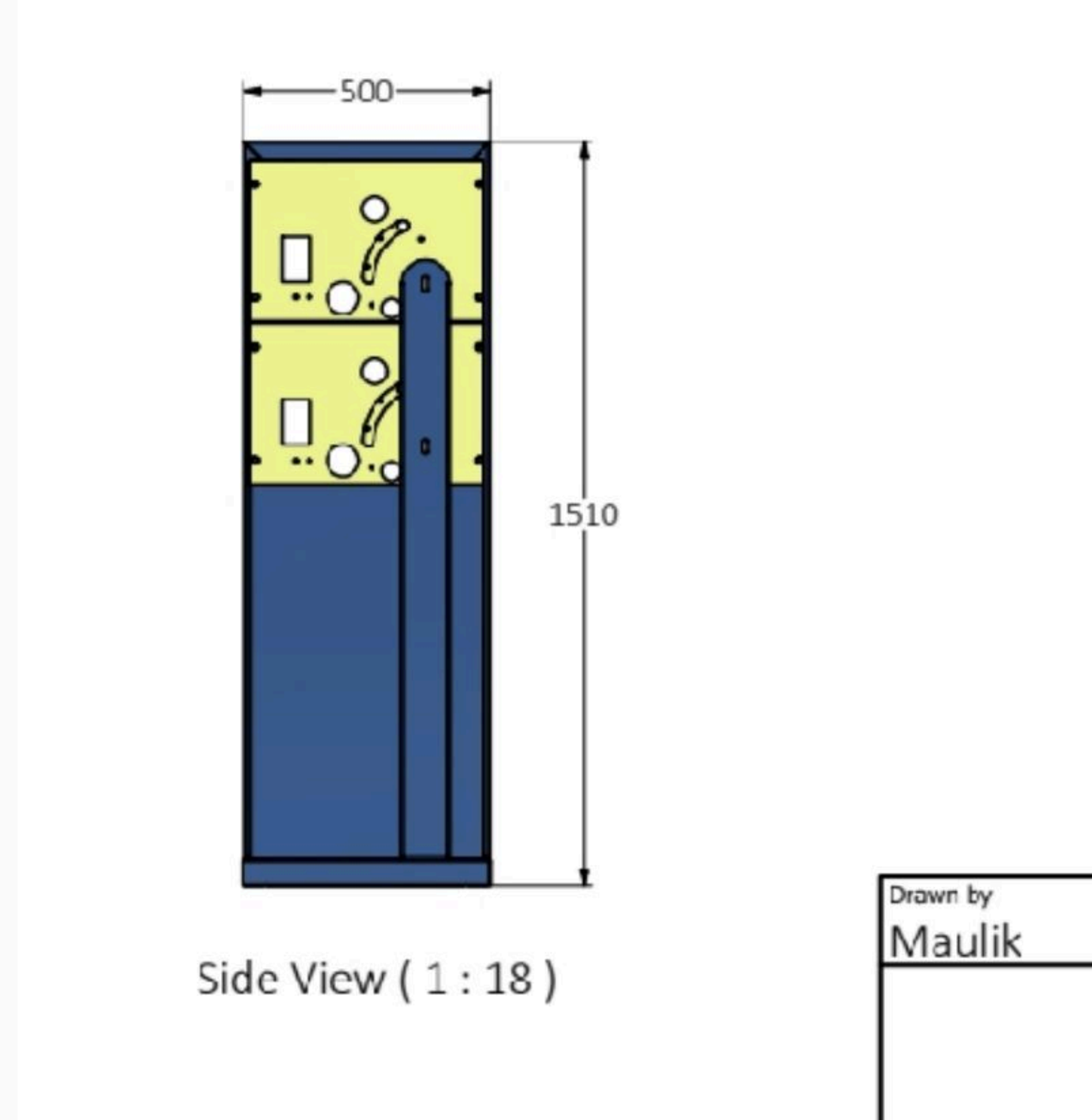

Drawn by	Checked by	Approved by	Date	Date
Maulik				14-02-2022
New Winding Machine				Sheet 1/3